

Haltemagnete

Scheibenform, mit Innengewinde

AUSFÜHRUNG

Gehäuse

Stahl, verzinkt

Magnetwerkstoff:

Hartferrit **HF**
temperaturbeständig bis zu 200 °C

SmCo **SC**

Samarium, Cobalt
temperaturbeständig bis zu 200 °C

NdFeB **ND**

Neodym, Eisen, Bor
temperaturbeständig bis 80 °C

INFORMATION

Haltemagnete GN 50.2 bilden in Kombination mit dem Stahlgehäuse und dem Kunststoffring ein System, welches den Magnet schirmt, verstärkt und den magnetischen Fluss optimal auf die Haftfläche umleitet.

- Weitere Erläuterungen zu Haltemagneten (siehe Seite 2022)



Ansicht auf Haftfläche

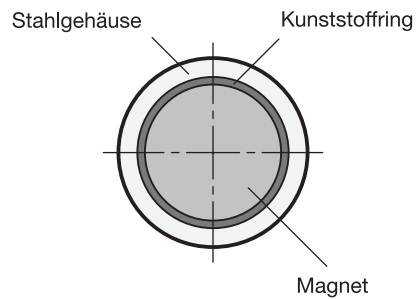
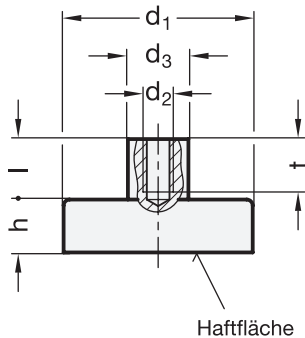

GN 50.2

Artikelnummer	d1	h	d2	d3	l	t	Nennhaftkräfte in N	⚖
GN 50.2-HF-10-4.5-M3	10 ±0.1	4.5 +0.2/-0.1	M3	6 ±0.1	7	5	4	3
GN 50.2-HF-13-4.5-M3	13 ±0.1	4.5 +0.2/-0.1	M3	6 ±0.1	7	5	10	4
GN 50.2-HF-16-4.5-M3	16 ±0.1	4.5 +0.2/-0.1	M3	6 ±0.1	7	5	18	6
GN 50.2-HF-20-6-M3	20 ±0.1	6 +0.2/-0.1	M3	6 ±0.1	7	5	30	11
GN 50.2-HF-25-7-M4	25 ±0.1	7 +0.3/-0.2	M4	8 ±0.2	8	7	40	20
GN 50.2-HF-32-7-M4	32 ±0.1	7 +0.3/-0.2	M4	8 ±0.2	8	7	80	31
GN 50.2-HF-36-7.7-M4	36 +0.2/-0.1	7.7 +0.3/-0.2	M4	8 ±0.2	8.3	7	100	42
GN 50.2-HF-40-8-M4	40 +0.2/-0.1	8 +0.3/-0.2	M4	8 ±0.2	8.5	7	125	57
GN 50.2-HF-40-8-M5	40 +0.2/-0.1	8 +0.3/-0.2	M5	10 ±0.2	10	8	125	61
GN 50.2-HF-47-9-M4	47 +0.2/-0.1	9 +0.4/-0.2	M4	8 ±0.2	8	7	280	86
GN 50.2-HF-47-9-M6	47 +0.2/-0.1	9 +0.4/-0.2	M6	12 ±0.2	11.5	10	180	91
GN 50.2-HF-50-10-M4	50 +0.2/-0.1	10 +0.4/-0.2	M4	8 ±0.2	8.5	7	220	105
GN 50.2-HF-50-10-M6	50 +0.2/-0.1	10 +0.4/-0.2	M6	12 ±0.2	12	10	220	110
GN 50.2-HF-57-10.5-M4	57 +0.2/-0.1	10.5 +0.5/-0.2	M4	8 ±0.2	8	7	280	147
GN 50.2-HF-57-10.5-M6	57 +0.2/-0.1	10.5 +0.5/-0.2	M6	12 ±0.2	12	10	280	153
GN 50.2-HF-63-14-M4	63 +0.3/-0.1	14 +0.5/-0.2	M4	8 ±0.2	8	7	350	228
GN 50.2-HF-63-14-M8	63 +0.3/-0.1	14 +0.5/-0.2	M8	15 ±0.2	16	14	350	240
GN 50.2-HF-80-10-M6	80 +0.3/0.1	10 +0.5/-0.2	M6	12 ±0.2	11.5	10	500	272
GN 50.2-HF-80-18-M6	80 +0.3/0.1	18 +0.5/-0.2	M6	12 ±0.2	10.5	10	600	477
GN 50.2-HF-80-18-M10	80 +0.3/0.1	18 +0.5/-0.2	M10	20 ±0.2	16	15	600	510
GN 50.2-HF-100-22-M12	100 +0.5/-0.1	22 +0.5/-0.2	M12	22 ±0.2	21	18	900	948
GN 50.2-HF-125-26-M14	125 +0.5/-0.1	26 +0.5/-0.2	M14	25 ±0.2	24	20	1300	1732
GN 50.2-SC-6-4.5-M3	6 ±0.1	4.5 ±0.1	M3	6 ±0.1	7	6	5	2
GN 50.2-SC-8-4.5-M3	8 ±0.1	4.5 ±0.1	M3	6 ±0.1	7	6	11	3
GN 50.2-SC-10-4.5-M3	10 ±0.1	4.5 ±0.1	M3	6 ±0.1	7	6	20	4
GN 50.2-SC-13-4.5-M3	13 ±0.1	4.5 ±0.1	M3	6 ±0.1	7	6	40	6
GN 50.2-SC-16-4.5-M4	16 ±0.1	4.5 ±0.1	M4	6 ±0.1	7	6	60	8
GN 50.2-SC-20-6-M4	20 ±0.1	6 ±0.1	M4	8 ±0.2	7	7	90	16
GN 50.2-SC-25-7-M4	25 ±0.1	7 ±0.2	M4	8 ±0.2	7	7	150	28
GN 50.2-SC-32-7-M5	32 ±0.1	7 ±0.2	M5	10 ±0.2	8.5	8	220	47
GN 50.2-ND-6-4.5-M3	6 ±0.1	4.5 ±0.1	M3	6 ±0.1	7	6	5	2
GN 50.2-ND-8-4.5-M3	8 ±0.1	4.5 ±0.1	M3	6 ±0.1	7	6	13	3
GN 50.2-ND-10-4.5-M3	10 ±0.1	4.5 ±0.1	M3	6 ±0.1	7	6	25	4
GN 50.2-ND-13-4.5-M3	13 ±0.1	4.5 ±0.1	M3	6 ±0.1	7	6	60	5
GN 50.2-ND-16-4.5-M4	16 ±0.1	4.5 ±0.1	M4	6 ±0.1	7	6	95	7
GN 50.2-ND-20-6-M4	20 ±0.1	6 ±0.1	M4	8 ±0.2	7	7	140	16
GN 50.2-ND-25-7-M4	25 ±0.1	7 ±0.2	M4	8 ±0.2	7	7	200	25
GN 50.2-ND-32-7-M5	32 ±0.1	7 ±0.2	M5	10 ±0.2	8.5	8	350	45
GN 50.2-ND-40-8-M6	40 +0.2/-0.1	8 ±0.2	M6	10 ±0.2	10	8	670	80
GN 50.2-ND-47-9.2-M6	47 +0.2/-0.1	9.2 ±0.2	M6	12 ±0.2	11.3	10	790	113
GN 50.2-ND-50-10-M8	50 +0.2/-0.1	10 ±0.2	M8	15 ±0.2	12	10	1000	158